

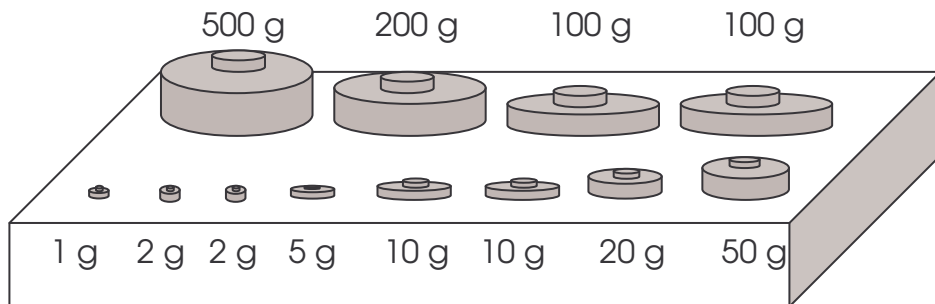

Voici une boîte de masses marquées :



Dessine les masses marquées qu'il faut utiliser pour peser chaque objet.

